

Eaton® ET5040 Crimp Machine



EATON

Powering Business Worldwide

Introduction

Eaton's ET5040 programmable crimp machine is the newest addition to Eaton's family of hose assembly equipment. The ET5040 is pre-programmed with all of Eaton's hose and hose fitting crimp specifications, crimp profile details, and machine settings in order to crimp to the required specifications. In addition, the machine advises the assembler which hose fittings are approved for each hose part number, and the dies required for each hose part number enabling the operator to manufacture factory quality hose assemblies.

Safety, improved ergonomics, increased hose size capability and ease of use were paramount with the design and development of the Eaton ET5040. The ET5040 includes state of the art crimp technology and electronics, utilizing touch screen operation with pre-loaded Eaton crimp specifications for virtually the entire portfolio of approved Eaton hose and flat crimp fitting combinations.

The ET5040 is capable of crimping hoses with an inside diameter of up to 4" and can crimp a wide range of products including Eaton textile braid, wire braid and spiral hydraulic, thermoplastic, Teflon, air conditioning, and industrial hose constructions. Adjustable telescoping legs provide improved line of site, allowing operators to adjust the crimp head to a height level that is most convenient

With pre-loaded crimp specifications and production intent capability, the ET5040 can be used for one-off assemblies or configured to run high volume production for any customer requirement. With just a touch of the screen, factory quality assemblies can be configured and built quickly and easily, resulting in increased throughput, improved delivery, and guaranteed quality.

*Teflon is a registered trademark of DuPont used under license by Eaton.



ET5040 Crimp Machine

Features (separate “optional” items)

- Programmable touch screen
- Pre-loaded Eaton crimp specifications
- Open throat horizontal crimp head
- Crimp capability:
 - Spiral Hose: up to 2” (DN51)
 - Braided Hose: up to 3” (DN80)
 - Industrial Hose: up to 4” (DN102)*
- Adjustable telescoping legs allow crimp height adjustment from 36”(914 mm) - 52”(1321 mm) (centerline of crimp)
- Die rack storage (machine or table top mount)
- Double pedal foot switch
- Backstop (manual or automatic)
- Grease free tooling with slide bearing technology
- Capable of crimping most Eaton hose styles, including:
 - Hydraulic braided and spiral
 - Textile braid
 - Thermoplastic
 - Teflon smooth and convoluted bore
 - 100R5
 - Air conditioning and refrigeration
 - Eaton Industrial
- ET5040 machines are supplied with required tooling for calibration
 - ET5040C-0019 calibration tool
 - ET5040C-0001 adapter die package
 - ET5040DC-M320S die

Benefits

- Easy to use: increases productivity
- Pre-loaded Eaton crimp specs reduces errors and scrap
- Fast and safe crimp operation
- Adjustable height provides line of site crimp and improved ergonomics
- Reduces set-up time for multiple crimps, increasing throughput
- Convenient die storage rack allows easy access to crimp dies and tooling
- Grease free dies allow for much easier and cleaner die changeout and reduces chance for operator error due to not having to apply grease to dies and crimp ring



*Contact Eaton on capability for fitting terminal end designs.

ET5040 Crimp Machine and Tooling Packages

Part No.	Package Description	Page
ET5040-001-230	ET5040 230V 3 Phase (50/60 Hz) Crimp Machine With Telescoping Legs (Includes Calibration Tooling)	5
ET5040-001-230KT	ET5040-001-230 Machine, Calibration Tooling, Die Installation Tool, Standard Die Package, Adapter Die Package, Double Foot Pedal and Machine Mounted Storage Rack	5
ET5040-001-380	ET5040 380V 3 Phase (50/60 Hz) Crimp Machine With Telescoping Legs (Includes Calibration Tooling)	5
ET5040-001-380KT	ET5040-001-380 Machine, Calibration Tooling, Die Installation Tool, Standard Die Package, Adapter Die Package, Double Foot Pedal and Machine Mounted Storage Rack	5
ET5040-001-400	ET5040 400V 3 Phase (50/60 Hz) Crimp Machine With Telescoping Legs (Includes Calibration Tooling)	5
ET5040-001-400KT	ET5040-001-400 Machine, Calibration Tooling, Die Installation Tool, Standard Die Package, Adapter Die Package, Double Foot Pedal and Machine Mounted Storage Rack	5
ET5040-001-420	ET5040 420V 3 Phase (50/60 Hz) Crimp Machine With Telescoping Legs (Includes Calibration Tooling)	5
ET5040-001-420KT	ET5040-001-420 Machine, Calibration Tooling, Die Installation Tool, Standard Die Package, Adapter Die Package, Double Foot Pedal and Machine Mounted Storage Rack	5
ET5040-001-440	ET5040 440V 3 Phase (50/60 Hz) Crimp Machine With Telescoping Legs (Includes Calibration Tooling)	5
ET5040-001-440KT	ET5040-001-440 Machine, Calibration Tooling, Die Installation Tool, Standard Die Package, Adapter Die Package, Double Foot Pedal and Machine Mounted Storage Rack	5
ET5040-001-460	ET5040 460V 3 Phase (50/60 Hz) Crimp Machine With Telescoping Legs (Includes Calibration Tooling)	5
ET5040-001-460KT	ET5040-001-460 Machine, Calibration Tooling, Die Installation Tool, Standard Die Package, Adapter Die Package, Double Foot Pedal and Machine Mounted Storage Rack	5
ET5040-001-480	ET5040 480V 3 Phase (50/60 Hz) Crimp Machine With Telescoping Legs (Includes Calibration Tooling)	5
ET5040-001-480KT	ET5040-001-480 Machine, Calibration Tooling, Die Installation Tool, Standard Die Package, Adapter Die Package, Double Foot Pedal and Machine Mounted Storage Rack	5
ET5040C-0001*†	Adapter Die Package (Supplied With ET5040 Crimp Machines. Required For Use With ET5040DC Style Dies and Used to All Calibrate Machine.)	7
ET5040C-0004*	Die Installation Tool	9
ET5040C-0006	Automatic Backstop	9
ET5040C-0007	Manual Backstop	9
ET5040C-0009	Viewing Mirror	9
ET5040C-0014*	Machine Mounted Die Storage Rack (Includes Insert Holders)	9
ET5040C-0016	Table Top Die Storage Rack (Includes Insert Holders)	9
ET5040C-0019*†	Calibration Tool (Supplied with ET5040 Crimp Machines)	9
ET5040C-0020*	Double Pedal Foot Switch	9
ET5040C-0022	430"U" Die Package	8
ET5040C-0023*	Includes 11 of the Most Popular Standard ET5040DC Style Die Sets	6
ET5040DC-M320S†	32mm Die Set	6
ET5040DC-MXXX	Standard Die Sets	6
ET5040PBL-MXXX	Large Bore Industrial Hose Die Sets	7
ET4001C-0017	Magnetic Work Lamp	9
Parts List		10

*Components included in machine kit packages "KT"

†Calibration tooling (supplied with all ET5040 base machines)

ET5040 Crimp Machine



***The ET5040 is shipped without oil in the reservoir.
Approved oil must be added prior to operation.**

Crimp Capacity

- Spiral Hose: up to 2" (DN51)
- Braided Hose: up to 3" (DN80)
- Industrial Hose: up to 4" (DN102)*

Mounting

- Free standing with adjustable telescoping legs

Size

- Legs fully extended (centerline of crimp head): 52" (1321 mm) high
- Legs fully retracted (centerline of crimp head): 36" (914 mm) high

Crimp Force

- 280 ton (2800 KN)

Reservoir Capacity

- 13.2 gallons (50 liters)

Hydraulic Oil*

- Industrial grade HM or HV46 ISO 6743/4

Total Weight (without mounting rack & dies)

- 1,047 lbs (475 Kg)

Available Power Options

- 230V 3 Phase 50/60 Hz
- 380V 3 Phase 50/60 Hz
- 400V 3 Phase 50/60 Hz
- 420V 3 Phase 50/60 Hz
- 440V 3 Phase 50/60 Hz
- 460V 3 Phase 50/60 Hz
- 480V 3 Phase 50/60 Hz

*Contact Eaton on capability for fitting terminal end designs.

ET5040 Dies and Kits

ET5040 Standard Die Part Numbers:

Capability of crimping Eaton hose products ranging from -3 (3/16") through -40 (2 1/2") in certain constructions. The ET5040-0023 kit includes the 11 most popular dies required to crimp Eaton's most common hose product lines. The standard ET5040DC dies require the use of the ET5040C-0001 adapter dies.

These die packages are used for hydraulic hoses and industrial hoses with a finished crimp diameter up to 3.46 in. (88mm).



Standard Die Set Part Numbers	Die Size		Die Length		Crimp Range			
					Minimum		Maximum	
	mm	in	mm	in	mm	in	mm	in
ET5040DC-M070S	7,0	0.276	82,0	3.23	7,0	0.28	9,0	0.35
ET5040DC-M090S	9,0	0.354	82,0	3.23	9,0	0.35	12,0	0.47
ET5040DC-M120S	12,0	0.472	82,0	3.23	12,0	0.47	15,0	0.59
ET5040DC-M150S*	15,0	0.590	82,0	3.23	15,0	0.59	18,0	0.71
ET5040DC-M180S*	18,0	0.709	82,0	3.23	18,0	0.71	21,0	0.83
ET5040DC-M210S*	21,0	0.827	82,0	3.23	21,0	0.83	24,0	0.95
ET5040DC-M240S*	24,0	0.945	82,0	3.23	24,0	0.95	28,0	1.10
ET5040DC-M280S*	28,0	1.102	82,0	3.23	28,0	1.10	32,0	1.26
ET5040DC-M320S††	32,0	1.259	82,0	3.23	32,0	1.26	37,0	1.46
ET5040DC-M355S	35,5	1.398	82,0	3.23	35,5	1.40	39,5	1.56
ET5040DC-M370S*	37,0	1.457	82,0	3.23	37,0	1.46	42,0	1.66
ET5040DC-M420S*	42,0	1.654	82,0	3.23	42,0	1.66	46,5	1.83
ET5040DC-M450S	45,0	1.772	82,0	3.23	45,0	1.77	50,0	1.97
ET5040DC-M465S*	46,5	1.831	82,0	3.23	46,5	1.83	52,0	2.05
ET5040DC-M505S	50,5	1.988	82,0	3.23	50,5	1.99	54,0	2.13
ET5040DC-M520S*	52,0	2.047	82,0	3.23	52,0	2.05	55,0	2.17
ET5040DC-M550S*	55,0	2.165	82,0	3.23	55,0	2.17	60,0	2.36
ET5040DC-M570S	57,0	2.244	82,0	3.23	57,0	2.24	64,0	2.52
ET5040DC-M590S	59,0	2.323	82,0	3.23	59,0	2.32	66,0	2.60
ET5040DC-M620S	62,0	2.441	82,0	3.23	62,0	2.44	70,0	2.76
ET5040DC-M690S*	69,0	2.717	82,0	3.23	69,0	2.72	73,0	2.87
ET5040DC-M720S	72,0	2.835	82,0	3.23	72,0	2.84	78,0	3.07
ET5040DC-M775S	77,5	3.051	82,0	3.23	77,5	3.05	85,5	3.37
ET5040DC-M790S	79,0	3.110	82,0	3.23	79,0	3.11	88,0	3.46

*Included in the ET5040-0023 standard die kit

††Supplied with ET5040 crimp machines and required for calibration

Require ET5040C-0001 adapter die

Each set includes 8 individual dies

ET5040 Dies and Kits

ET5040C-0001 Adapter Dies:

Eaton adapter dies are supplied with all ET5040 base machines and are required for use with Eaton standard ET5040DC style dies. Adapter dies are inserted into the crimp head, providing proper alignment for the ET5040DC style dies. ET5040DC style dies are installed directly into the adapter die segments, which are referenced on page 6.



ET5040 Large Bore Die Part Numbers:

Capability of crimping Eaton hose products ranging up to -64 (4") in certain constructions. The large bore ET5040 dies do not require an adapter die and are inserted one segment at a time. The large bore dies are typically used for large I.D. Eaton Industrial hose and -48 two wire braid hose.



Standard Die Set Part Numbers	Die Size		Die Length		Crimp Range			
					Minimum		Maximum	
	mm	in	mm	in	mm	in	mm	in
ET5040PBL-M710	71,0	2.795	118,0	4,65	71,0	2.80	78,0	3.07
ET5040PBL-M740	74,0	2.913	118,0	4,65	74,0	2.92	83,0	3.26
ET5040PBL-M780	78,0	3.070	118,0	4,65	78,0	3.07	86,0	3.38
ET5040PBL-M840	84,0	3.307	118,0	4,65	84,0	3.31	92,0	3.62
ET5040PBL-M860	86,0	3.386	118,0	4,65	86,0	3.39	94,0	3.70
ET5040PBL-M900	90,0	3.543	118,0	4,65	90,0	3.55	99,0	3.89
ET5040PBL-M960	96,0	3.800	118,0	4,65	96,0	3.80	105,0	4.13
ET5040PBL-M1030	103,0	4.055	118,0	4,65	103,0	4.06	113,0	4.44
ET5040PBL-M1060	106,0	4.173	126,0	4.96	106,0	4.18	116,0	4.56
ET5040PBL-M1110	110,0	4.331	126,0	4.96	110,0	4.33	121,0	4.76
ET5040PBL-M1160	116,0	4.567	126,0	4.96	116,0	4.57	127,0	4.99
ET5040PBL-M1210	121,0	4.764	126,0	4.96	121,0	4.77	133,0	5.23
ET5040PBL-M1260	126,0	4.961	126,0	4.96	126,0	4.96	138,0	5.43
ET5040PBL-M1310	131,0	5.157	126,0	4.96	131,0	5.16	144,0	5.66

Each set includes 8 individual dies

ET5040 Dies and Kits

ET5040 430 "U" Series Die Part Numbers:

Capable of crimping Weatherhead 430 "U" series fittings ranging from -08 (1/2") through -32 (2").



430 "U" Die Set Part Numbers	430 "U" Fitting Size	Die Size		Die Length		Crimp Range			
						Minimum		Maximum	
		mm	in	mm	in	mm	in	mm	in
ET5040DC-M210S	43006"U" Fittings	21,0	0.827	82,0	3.23	21,0	0.83	24,0	0.95
ET5040DC-08U*	43008"U" Fittings	28,0	1.102	82,0	3.23	28,0	1.10	32,0	1.26
ET5040DC-M280S	43010"U" Fittings	28,0	1.102	82,0	3.23	28,0	1.10	32,0	1.26
ET5040DC-12U*	43012"U" Fittings	32,0	1.259	82,0	3.23	32,0	1.26	36,0	1.41
ET5040DC-16U*	43016"U" Fittings	42,0	1.653	82,0	3.23	42,0	1.65	46,0	1.81
ET5040DC-20U*	43020"U" Fittings	52,0	2.047	82,0	3.23	52,0	2.05	57,0	2.24
ET5040DC-24U*	43024"U" Fittings	57,0	2.244	82,0	3.23	57,0	2.24	62,0	2.44
ET5040DC-32U*	43032"U" Fittings	69,0	2.716	82,0	3.23	69,0	2.72	75,0	2.95

*Included in the ET5040-0022 430 "U" Series die kit
 Require ET5040C-0001 adapter die
 Each set includes 8 individual dies

ET5040 Crimp Components and Accessories

ET5040C-0014 Machine Mounted Die Storage Rack



Machine mounted die storage rack provides quick and easy access to crimp dies, resulting in improved setup time and crimp speed.

ET5040C-0016 Table Top Die Storage Rack



Table top die storage provides flexible storage in the shop and allows placement of dies where easy access and space are available.

ET5040C-0006 Automatic Backstop

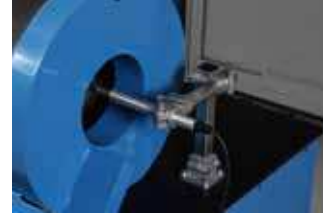

Electronic automatic backstop initiates crimp sequence and provides consistent and accurate crimping for high volume production.

ET5040C-0007 Manual Backstop



Manual backstop ensures crimp length and position are set for consistent and repeatable crimps each and every time.

ET5040C-0020 Double Pedal Foot Switch



Double pedal foot switch provides hands free operation of the crimp head, allowing for both crimp and retract during operation.

ET5040C-0004 Die Installation Tool



Die installation tool provides quick die change out capability for all standard, and 430"U" style dies.

ET5040C-0019 Calibration Tool



Calibration tool simplifies the calibration process to ensure the ET5040 crimp machine is achieving consistent and accurate crimp diameters (supplied with machine).

ET4001C-0017 Magnetic Work Lamp



Versatile magnetic work lamp can be mounted in multiple locations, providing additional light to improve visibility while crimping assemblies.

ET5040C-0009 Viewing Mirror



Machine mounted viewing mirror provides additional line of site to the crimp head to assist with fitting alignment and crimp location.

ET5040 Crimp Machine Repair and Replacement Items

Item No.	Part Number	Description
1	ET5040C-0017	Telescopic Leg
2	ET5040C-0034	Pin (Telescopic Leg)
#	ET5040C-0003	Detent Pins
#	ET5040C-0004	Die Installation Tool
#	ET5040C-0012	Die Tool Insert Holder
#	ET5040C-0019	Calibration Tool
#	E-MQCR-TT002-E	Owner's Manual

Item not illustrated in parts breakdown

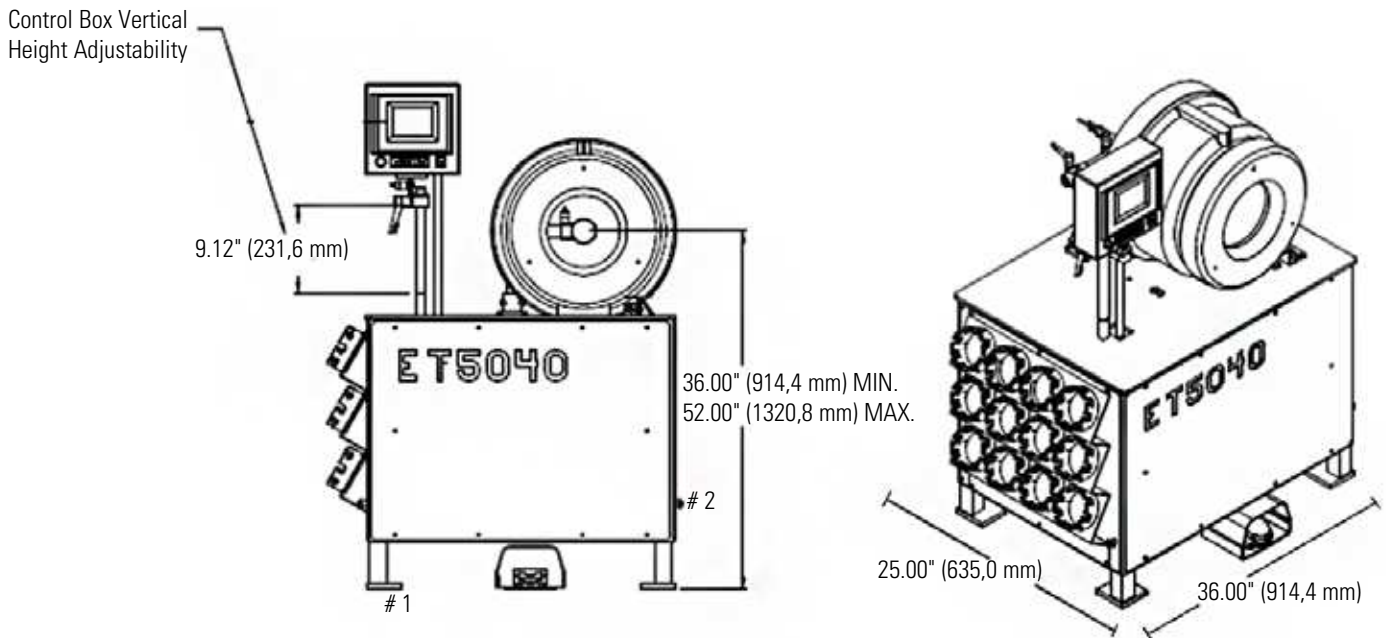

Eaton's Hose and Fitting Assembly Product Warning

Flexible hose lines offer many advantages over rigid tubing including routing ease, vibration absorption, sound deafening and the ability to accommodate movement of connected components. However, hose lines require caution in use not only to provide long service, but also to guard against potentially dangerous failure.

Important

The user should carefully observe the precautions listed in this catalog, including the recommendations on the selection of hose and fittings on the relevant pages, and the pages on fluid compatibility. In addition, care should be taken not to exceed the minimum bend radius listed for each hose size and type in the hose section. Maximum operating pressure should not exceed pressures listed in the hose data. Instructions for assembling fittings to different hose should be followed carefully to ensure the performance of the completed assembly.

WARNING

Eaton fitting tolerances are engineered to match Eaton's hose tolerances. The use of Eaton fittings on hose supplied by other manufacturers and/or the use of Eaton's hose with fittings supplied by other manufactures may result in the production of unreliable and unsafe hose assemblies and is neither recommended nor authorized by Eaton or any of its affiliates or subsidiaries.

WARNING

Application considerations must be observed in selecting appropriate components for the application of these products contained herein. The failure to follow the recommendations set forth in this catalog may result in an unstable application which may result in serious personal injury or property damage.

EATON OR ANY OF ITS AFFILIATES OR SUBSIDIARIES SHALL NOT BE SUBJECT TO AND DISCLAIMS ANY OBLIGATIONS OR LIABILITIES (INCLUDING BUT NOT LIMITED TO ALL CONSEQUENTIAL, INCIDENTAL AND CONTINGENT DAMAGES) ARISING FROM TORT CLAIMS (INCLUDING WITHOUT LIMITATION NEGLIGENCE AND STRICT LIABILITY) OR OTHER THEORIES OF LAW WITH RESPECT TO ANY HOSE ASSEMBLIES NOT PRODUCED FROM GENUINE EATON HOSE FITTINGS, HOSE AND EATON APPROVED EQUIPMENT, AND IN CONFORMANCE WITH EATON'S PROCESS AND PRODUCT INSTRUCTIONS FOR EACH SPECIFIC HOSE ASSEMBLY.

Failure to follow these processes and product instructions and limitations could lead to premature hose assembly failures resulting in property damage, serious injury or death.

Eaton
Hydraulics Business USA
14615 Lone Oak Road
Eden Prairie, MN 55344
USA
Tel: 952-937-9800
Fax: 952-294-7722
www.eaton.com/hydraulics

Eaton
Hydraulics Business Europe
Route de la Longeraie 7
1110 Morges
Switzerland
Tel: +41 (0) 21 811 4600
Fax: +41 (0) 21 811 4601

Eaton
Hydraulics Group Asia Pacific
Eaton Building
No.7 Lane 280 Linhong Road
Changning District,
Shanghai 200335
China
Tel: (+86 21) 5200 0099
Fax: (+86 21) 2230 7240

