

EATON

Hydraulics

ET1000 Crimp Machine

Operator's Manual

Portable
Light Duty
Positive Stop



Table of Contents

Safety Instructions	2
Specifications	3
Accessories	3
Set-up and Assembly	3
Operating Instructions	
Description of Components	4
Crimping Procedures (large collets)	4
Crimping Procedures (small collets)	5
Maintenance	
Maintenance Intervals	6
Machine Maintenance Procedures	6
Crimp Machine Components	7

Safety Instructions

Read and understand the operator's manual before attempting to operate any equipment.

WARNING Aeroquip hose, hose fittings and assembly equipment should be used only with other Aeroquip hose, hose fittings and assembly equipment and Weatherhead hose, hose fittings and assembly equipment should be used only with Weatherhead hose, hose fittings and assembly equipment. Do not combine or use Aeroquip or Weatherhead hose, hose fittings and assembly equipment with each other, i.e. Aeroquip hose with Weatherhead fittings, or with hose, hose fittings or assembly equipment supplied by another manufacturer.

Eaton hereby disclaims any obligation or liability (including incidental and consequential damages) arising from breach or contract, warranty, or tort (under negligence or strict liability theories) should Aeroquip or Weatherhead hose fittings or assembly equipment be used **interchangeably** or with **any** hose, fittings or assembly equipment supplied by another manufacturer, or in the event that product instructions for each specified hose assembly are not followed.

WARNING Failure to follow process and product instructions and limitations could lead to premature hose assembly failures, resulting in property damage, serious injury or death.

Aeroquip and Weatherhead fitting tolerances are engineered to match Aeroquip and Weatherhead hose tolerances. The combination or use of Aeroquip or Weatherhead hose and hose fittings with each other, i.e. Aeroquip hose with Weatherhead fittings, or with hose or fittings supplied by another manufacturer may result in the production of unreliable and/or unsafe hose assemblies and is neither recommended nor authorized by Eaton.

Safety Instructions

1. PREVENT UNAUTHORIZED OPERATION. Do not permit anyone to operate this equipment unless they have read and thoroughly understand this manual.
2. WEAR SAFETY GLASSES.
3. AVOID PINCH POINTS. Do not rest your hand on the crimp ring. Keep your hands clear of all moving parts. Do not allow anyone, other than the operator, close to the equipment while it is in operation.
4. MAINTAIN DIES WITH CARE. Dies used in the ET1000 crimp machine are hardened steel, offering the best combination of strength and wear resistance for long life. Hardened dies are generally brittle and care should be taken to avoid any sharp impact. Never strike a die with a hardened instrument.
5. USE ONLY SPECIFIED AEROQUIP/WEATHERHEAD PRODUCTS. Make hose assemblies using only Aeroquip and Weatherhead hose and fittings specified for this assembly equipment.
6. VERIFY CORRECT CRIMP DIAMETERS. Check and verify correct crimp diameters of all fittings after crimping. Do not put any hose assemblies into service if the crimp diameters do not meet Eaton crimp specifications.
7. Make sure all dies are completely in place, the spacer ring rests against the placement pins, and the pusher is pulled forward into the detent position before crimping.
8. DO NOT OVER PRESURIZE. Do not exceed the 10,000 psi hydraulic pressure supplied to the machine.

NOTE: All components used to connect the pump and crimp cylinder must meet the criteria set forth in the Material Handling Institute Specification #IJ100 for hydraulic jacking applications.

9. DIE CHANGE. DO NOT INSERT/REMOVE DIES WHILE THE POWER IS ON OR MACHINE IS IN OPERATION.
10. SECURE THE EQUIPMENT TO A STABLE WORK SURFACE. Prior to operation, secure the crimp machine to a stable work surface to prevent the equipment from tipping.
11. UNPLUG THE POWER SUPPLY WHEN NOT IN USE.
12. KEEP WORK AREA CLEAN. Cluttered areas and benches invite accidents.

Specifications and Accessories

NOTE:

Your new crimp machine has been calibrated and filled with hydraulic oil in the factory. Do not remove any plugs or caps until necessary. Excess air in the hydraulic system may cause erratic cylinder movement during retraction. Refer to the Setup and Assembly section for instructions on removing air from the hydraulic system.

Specifications

Crimper Dimensions:
22" tall x 16" width x 14" deep

Weight: 70 lbs. (machine & stand only)

Pump Requirements:

- Reservoir Capacity: 36 cu. in (590 cc)
- Pressure Rating: 10,000 psi (690 bar)
- The air/hydraulic pump requires a minimum of 100psi to operate at maximum efficiency.

Hose Production Capacity:
(varies with available tooling)

Accessories

- Die Cage/Collet, spacer ring tool box (Part # FT1603)
- Die Cage/Collet, spacer ring wall mount rack (Part # FT1604)
- High Performance PTFE Lubricant (Part # 140-06701)

Setup and Assembly

1. Your new ET1000 crimp machine comes disassembled for ease of shipment. Before use, the machine must be assembled to the base with the supplied fasteners (ET1000C-0008).
2. Remove the plug from the top cylinder port and install the -06 size ORB, 90 degree adapter using 23-24 ft. lbs. assembly torque. Orient the adapter so that it points to the rear of the crimp machine, away from the operator.
3. Install the pump connecting hose assembly to the cylinder adapter with the -06 size 37 degree swivel nut fittings using 18-20 ft. lbs. assembly torque.
4. Do not exceed an 8" minimum bend radius of the pump connecting hose when attaching the hose to the pump and cylinder.
5. If using your own pump, make sure it has the requirements listed in the Specifications section above.
6. Place the pump on the work surface to either side of the crimp machine. (Note: if using the air/hydraulic pump, the pump can be fastened to either side of the crimp machine frame as you face the front of the crimp machine.) Install the 90 degree adapter to the pump pressure port (Male NPTF threads should be tightened following the hex-marking procedure of 2 to 3 turns past hand tight).
7. Remove excess air from the hydraulic system. This can be accomplished by placing the pump at a higher level than the cylinder and cycling the machine approximately five times.
8. Secure the machine frame to a stable work surface using lag screws or other suitable fasteners.

Operating Instructions

Description of Components



ET1000 Crimp Machine



Die Ring Adapter

Split Collet Assembly



Spacer Rings

Crimping Procedures (using larger collets)



Step 1:

Slide the pusher to the back position.

Using the Collet/Spacer Ring Selector Chart, select the proper collet assembly and spacer ring.

Lubricate the inside cone of the die ring and external surfaces of the collet assembly with a high-efficiency PTFE based lubricant.

Insert the collet assembly into the base die ring.

Step 2:

Insert the hose assembly through the bottom of the base die ring and between the two collet assembly halves. Align the fitting with the top of the collet halves as referenced on the Collet/Spacer Ring Selector Chart.

Step 3:

Place the spacer ring in the appropriate position on top of the collet assembly (either flat-side up or flat-side down as referenced in the Collet/Spacer Ring Selector Chart).

Step 4:

Pull the pusher forward into the detent holding position with the pusher positioning handle.

Step 5:

Begin crimping by actuating the pump. **When the spacer ring bottoms out against the base die ring,** the crimping is complete. (NOTE: Visually inspect the crimp and verify the correct crimp diameter and length.)

Operating Instructions

Crimping Procedures (using smaller collets)



Step 1:

Slide the pusher to the back position.

Using the Collet/Spacer Ring Selector Chart, select the proper collet assembly and spacer ring.

Lubricate the inside cone of the base die ring and the outside cone of the die ring adapter plate.

Place the die ring adapter plate into the base die ring.



Step 2:

Lubricate the external surfaces of collet assembly halves with a high-efficiency PTFE- based lubricant.

Insert the collet assembly into the die ring adapter plate.



Step 3:

Insert the hose assembly through the bottom of the base die ring and up between the two collet assembly halves. Align the fitting with the top of the collet halves as referenced on the Collet/Spacer Ring Selector Chart.



Step 4:

Place the spacer ring in the appropriate position on top of the collet assembly (either flat-side up or flat-side down as referenced in the Collet/Spacer Ring Selector Chart).



Step 5:

Pull the pusher forward into the detent holding position with the pusher positioning handle.

Step 6:

Begin crimping by actuating the pump. **When the spacer ring bottoms out against the die ring adapter plate**, the crimping is complete. (NOTE: Visually inspect the crimp and verify the correct crimp diameter and length.)

Maintenance

Maintenance Intervals

Collet Assembly & Die Ring Adapter Plate Lubrication:

Every 30 crimps =
Re-lubricate sliding surfaces of dies
Every 250 crimps = Remove old grease and re-lubricate

Base Die Ring & Die Ring Adapter Plate Maintenance:

Every 250 crimps = Remove old grease and re-lubricate
Every 1,000 crimps = Remove old grease, inspect for wear or damage and re-lubricate if okay.

Machine Maintenance Procedures

1. Sliding surfaces must be kept free of dirt and other abrasive materials.
2. All exposed black metal surfaces should be coated occasionally with a light film of oil to prevent corrosion.
3. Some fitting/hose combinations require full pump reservoir capacity to complete the crimp cycle. The oil level in the fluid reservoir of the hydraulic pump should be checked periodically and refilled as required with the pump manufacturer's hydraulic oil as needed.

NOTE: Completely retract the cylinder when checking the oil level.

Crimp Machine Components

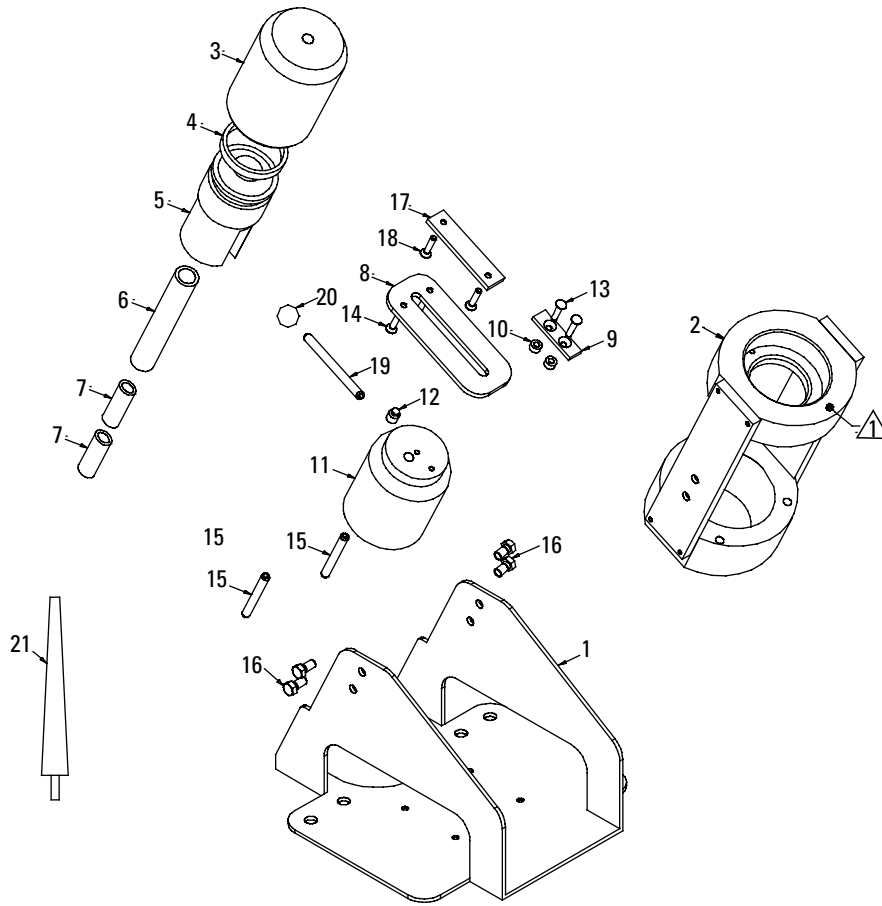

ITEM	PART NO.	DESCRIPTION	QTY	ITEM	PART NO.	DESCRIPTION	QTY
1	ET1000C-0001	Base	1	12	140-06602	Detent Screw	1
2	ET1000C-0002	Die Ring	1	13	140-15984-01	Flat Head Cap Screw	2
3	ET1000C-0003	Cylinder Cap	1	14	140-15983-01	Flat Head Cap Screw	2
4	140-05691	T Ring Seal	1	15	120-70188-41	Split Roll Pin	2
5	ET1000C-0004	Piston	1	16	ET1000C-0008	Hex Head Bolt	4
6	ET1000C-0005	5 in. Spring	1	17	140-05687	Spring Retainer	1
7	140-15962	3 1/2 in. Spring	2	18	140-15984	Flat Head Cap Screw	2
8	140-05688	Slide Plate	1	19	140-05695	Slide Pull Rod	1
9	140-06924	Flange Slide Plate	1	20	140-05694	Slide Pull Knob	1
10	140-06925	Bushing Slide Plate	2	21	140-06701	1.5 oz. Grease	1
11	ET1000C-0006	Pusher	1				

Eaton
14615 Lone Oak Road
Eden Prairie, MN 55344
USA
Tel: 952 937-9800
Fax: 952 974-7722
www.hydraulics.eaton.com

Eaton
20 Rosamond Road
Footscray
Victoria 3011
Australia
Tel: (61) 3 9319 8222
Fax: (61) 3 9318 5714

Eaton
Dr.-Reckeweg-Str. 1
D-76532 Baden-Baden
Germany
Tel: (49) 7221 682-0
Fax: (49) 7221 682-788



Hydraulics

© 2003 Eaton Corporation
All Rights Reserved
Printed in USA
Document No. E-EQCR-TM001-E
September 2003